

軸用C型止め輪(スナップリング)

HASHIMA

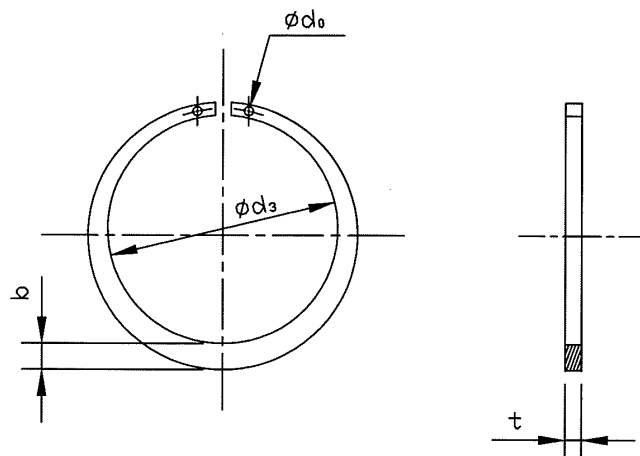

単位: mm

呼び径	止 め 輪 寸 法					
	d_3		t		b	d_0
	寸法	公差	寸法	公差	約	最小
S-	310	293	6		17	5
	320	303			17	
	330	313			18	
	340	323			18	
	350	333			19	
	360	343			19	
	370	353			19	
	380	363			19	
	390	373			19	
	400	383			19	
	410	390	7	± 0.2	23	6
	420	400			23	
	430	410			23	
	440	420			23	
	450	430			23	
	460	440			24	
	470	450			24	
	480	460			24	
	490	470			24	
	500	480			24	
	510	485	8		25	6
	520	495			25	
	530	505			25	
	540	515			25	
	550	525			25	
	560	535			26	
	570	545			26	
	580	555			26	
	590	565			26	
	600	575			26	

上記品は、受注生産品です。